

OPEN

Compute Project

**Scaleable
300KW Modular Data Center
Specification**

Author: Roberto Söderhäll Chief Business Development Officer, Swedish Modules

Author: Markus Tietäväinen, Pre-engineering & Construction Swedish Modules

License

This specification is contributed under the OCP Contributor Licensing Agreement (OCP-CLA) by the following entities:

Swedish Modules

Limitations of the OCP CLA license are noted below:

NONE

You can review the signed copies of the OCP-CLA for this specification on the OCP website. <http://www.opencompute.org/products/specsanddesign>

Usage of this specification is governed by the OCPHL permissive.

You can review this license at <http://www.opencompute.org/participate/legal-documents/>

Your use of this Specification may be subject to other third-party rights. THIS SPECIFICATION IS PROVIDED "AS IS." The contributors expressly disclaim any warranties (express, implied, or otherwise), including implied warranties of merchantability, non-infringement, fitness for a particular purpose, or title, related to the Specification. The entire risk as to implementing or otherwise using the Specification is assumed by the Specification implementer and user. IN NO EVENT WILL ANY PARTY BE LIABLE TO ANY OTHER PARTY FOR LOST PROFITS OR ANY FORM OF INDIRECT, SPECIAL, INCIDENTAL, OR CONSEQUENTIAL DAMAGES OF ANY CHARACTER FROM ANY CAUSES OF ACTION OF ANY KIND WITH RESPECT TO THIS SPECIFICATION OR ITS GOVERNING AGREEMENT, WHETHER BASED ON BREACH OF CONTRACT, TORT (INCLUDING NEGLIGENCE), OR OTHERWISE, AND WHETHER OR NOT THE OTHER PARTY HAS BEEN ADVISED OF THE POSSIBILITY OF SUCH DAMAGE.

Table of Contents

License	2
Table of Contents	3
Overview	4
Module Specification Summary	5
Module Structure Specification	6
Electrical System Specification	9
Cooling System Specification	9
Supporting Systems	10
Transportation	10
Site Preparation	11
Onsite Module Deployment	12
Operations and Maintenance	12
Appendix A	13
Example Drawings	13
Revision History	19

Overview

This prefabricated modular data center specification is a scalable solution design, optimized for deploying Open Compute hardware in sites with a requirement for 20 racks or more.

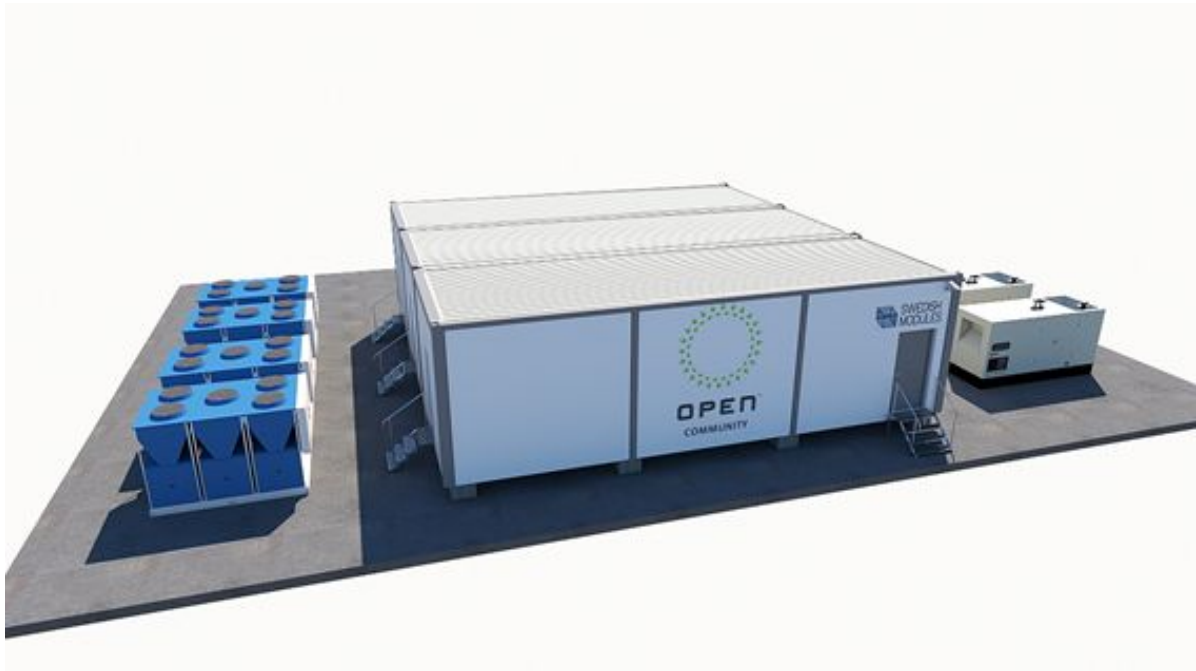

Module Specification Summary

Description	Specification	Comments
IT-load [kW] (total capacity)	300-500	CW InRow Coolers and N+1 redundancy
Number of Racks (total capacity)	28 / 30	@300 kW With UPS / Without UPS
	26 / 28	@500 kW With UPS / Without UPS
Average Density (kW/Rack)	10-18	With UPS and CW InRow Coolers specified to meet airflow capacity requirements
Maximum Density (kW/Rack)	20	
Module Size[mm] (LxWxH)	13650 x 4750 x 4100	Outside dimensions
Module Size[mm] (LxWxH)	13350 x 4450 x 3550	Internal dimensions
Module Weight [kg] (*Empty/Full)	20350 / 57350	Empty = no IT racks or equipment Full = 30 racks @ 1500 kg
Input Power Type	400V, 5 wire, 500 amp	AC Low Voltage
Cooling System	InRow CW, N+1	DX option available
pPUE example 1 City Stockholm SE	1.070 / 1.178	With CW free cooling chiller / With DX
pPUE example 2 City Dubai	1.227 / 1.224	With CW free cooling chiller / With DX
Scalable Yes/ No	Yes	Easy deployment and scalability on site side by side or stackable three stories high

Module Structure Specification

1. General

a. Module Dimensions

- i. All materials and workmanship are of a suitable type and quality to ensure that the modular data center will operate satisfactorily and accordance with this specification.
- ii. Outside dimensions 13650 x 4750 x 4100 (LxWxH)
- iii. Internal dimensions 13350 x 4450 x 3550 (LxWxH)
- iv. The module and all fittings installed therein will be suitable for transport on paved dirt roads and standard sea freight.
- v. This document is to detail the basic requirements.
- vi. Module Enclosure shall be designed and built to meet IP55 according to EN60529.

2. Construction

a. Frame

- i. Module is built on a steel frame with a bottom frame.
- ii. The enclosure frame design is formed from three primary elements, a structural base, a frame support for walls, and a frame support for the roof suitable for environmental and equipment loads specified within this document.
- iii. The primary structural element of the enclosure base is formed from structural steel at the outer edge of the base of the enclosure. Wall frame constructed of structural framing system to support wall panels, roof, and roof mounted equipment as specified within this document.
- iv. Steel frame shall be sandblasting or chemically cleaned and treated with a layer of antioxidant primer
- v. Module base and upper frame shall be designed to support all floor mounted equipment and suspended systems (hanging all fire suppression and detection equipment as well as wiring trays, hot/cold aisle containment, and overhead cooling equipment) in addition to lifting and transportation stresses and specified environmental conditions.
- vi. Minimum 4 lifting points, each corner column shall be equipped with a welded plate with M64 thread (or equivalent).
- vii. Module has 8 loading points that needs support, plinths or foundation, concrete or steel.

b. Roof, Walls & Floor

- i. Exterior roof designed to withstand the environmental loading while maintaining weatherproofing, preventing ponding, and diverting rainwater from roof. The module should offer thermal and fire protection as required by local codes.

- ii. Exterior walls (typ): 80-150 mm thick insulated panels, with a minimum thermal resistance of 0.470 W/m²k
 - iii. Interior ceiling(typ): 145mm thick insulated panels, , with a minimum thermal resistance of 0.470 W/m²k
 - iv. Floor: steel plate, with anti-static floor surface, insulating thermal barrier barrier required (ie. rockwool, sprayfoam)
 - v. Fire resistance (if required): EI60, per EN 13501-2
 - vi. The flooring on base frame shall be designed to allow equipment to be mechanically bolted to the floor to avoid tipping or damage during shipment
- c. Exterior Protection and Finish
- i. Module Enclosure shall be designed and built to meet a minimum of IP55 according to EN60529.
 - ii. Coating: all exposed steel has a C3 or C4 coating, depending on installation environment (Per ISO 12944 standard)– external roof and exposed beams top frame, and bottom frame.
 - iii. Internal and steel that is built in or covered have an C1 coating (Per ISO 12944 standard).
- d. External Doors
- i. The module doors shall fulfill all regular use requirements and emergency exit requirements.
 - ii. The doors shall be made of steel and painted and protected against rust.
 - iii. Doors must have panic bar, provisions for electronic monitoring, and automatic closure.
 - iv. Doors are RC2 break-in resistance level in accordance with EN 1627/1630.
 - v. Doors must meet local fire hour rating requirements
- e. Load Requirements
- i. Wind loading - Wind pressure 1.7kN/m² with a span of 4.5m Eurocode EN1991-1-4, applied to the walls of the enclosure.
 - ii. Wind suction 1.6 kN/m² with a span of 4.5m
 - iii. Floor Loading: Withstand floor loads up to 1000kg/m² across the entire floor structure.
 - iv. Roof/Snow Load: 245 kg/m² on the roof (minimum)
 - v. Shock-Load: Withstand normal transportation conditions before installation on the site, without deformation or damage. Shock of 2g, 10 millisecond duration for transport conditions per IEC 60068-2-64.
- f. Stackability
- i. This module is stackable up to three stories high, side by side.
- g. External Connections
- i. Input Power: 400 VAC, 5 wire, 500 Amp hard wired.
 - ii. Backup Power: Provisions for weatherproof connections for (2) 400kW Generators.

- iii. Cooling: Provisions for weatherproof connections of CW piping to external chillers or DX condensing pipes to external condensers.
- h. Internal Environmental Conditions
 - i. The internal conditions will maintain ASHRAE 90.1 for recommended, fresh air, temperature and humidity ranges.
- i. External Environmental Conditions
 - i. The internal conditions will maintain ASHRAE 90.1 for recommended, fresh air, temperature and humidity ranges.
- j. Altitude
 - i. Sea level is used for the referred pPUE figures in the document.
 - ii. Power and cooling system capacity must be derated based on site altitude.

Interior Layout

- 1. IT Space
 - a. Cabling pathway
 - i. Above racks with power and data network cables on separate ladders/baskets
 - b. Aisle spacing
 - i. 1200mm in the cold aisle (minimum with specified max rack depth)
 - ii. 675mm in the hot aisle (min)
 - iii. Access to hot aisle when required, under supervision and restricted periods.
 - c. Rack row must accommodate a maximum of height of 2400mm and depth of 1070mm.
 - d. Air containment: Physical isolation of hot or cold aisles required to maintain maximum efficiency
 - e. Access & exit: The number of required exits shall meet local codes. At least one entry door shall be large enough to accommodate the removal/installation of racks or other equipment.
 - f. If racks are to be installed or moved while fully loaded with equipment, additional provisions, such as point floor loads and smooth floor transitions.
- 2. Facility Space
 - a. The following items are typically located in a designated area for data center facility support
 - i. Main input paneled accessible with front access
 - ii. House loads panel
 - iii. Control & monitoring panels
 - iv. Humidification/dehumidification equipment and controls
 - v. Security/fire suppression/alarm panels
 - b. The space designated for supporting the data center facilities shall be design to meet maintenance clearances as defined by local codes.

Electrical System Specification

1. Electrical System Description

- a. Main power input from the power grid supported with two redundant Diesel Generators, connected to an ATS. With UPS system included the UPS is configured with internal redundancy by using power modules N+1. AC power feed to Open racks via Busway or cable to rack mounted rectifiers for DC 48V to the IT-equipment.
- b. Main Input Panel: 400V three-phase electrical panel, TN-S construction type. Panel incorporates (2) 500A main breakers. The panel will distribute power to all critical and non-critical loads. The main panel includes the capability to monitor the input power for all incoming feeds into the module and Ethernet gateway for external monitoring
- c. Critical AC power distribution feeds from UPS to OCP racks can be delivered via overhead busway or end-row PDU at N or 2N redundancy (based on customer requirements) to rack mounted rectifiers for DC 48V to the IT-equipment.
- d. Non-Critical Panel - Size appropriate 400V three phase electrical panels support loads that do not require UPS protected power such as house loads, fire suppression, and cooling units.
- e. Auxiliary equipment (house loads)
 - i. Lighting: LED light fixtures providing a minimum of 300 lux measure at the front and rear of the rack rows
 - ii. Emergency lighting: Exit Sign/Emergency lighting block mounted above each door at the aisle containment system and module entry/exit doors
 - iii. Electrical convenience outlets as required by local codes for maintenance
 - iv. Fresh air ventilation system
 - v. Fire suppression/detection control panel
 - vi. Security/access panel
- f. Grounding/Bonding
 - i. All internal components will be grounded to a common internal copper busbar. The module is designed to connect to a TN-S type grounding system.
 - ii. External copper ground bar will be provided on the outside of the module for attachment of earthing ground on-site by customer.
 - iii. Earth bolts attached to every corner columns and connection between modules with flat copper bar.

Cooling System Specification

1. Cooling System Description

- a. Type: Chilled water
 - b. Units: (12) Units/ Module, which can provide up to 27kW of sensible cooling each
 - c. Redundancy: N+1
 - d. DX cooling available as an option
2. Module External Cooling Connections
 - a. Piping from internal cooling units shall terminate on the exterior of the module for ease of on-site connection to condensers or chillers. Pipe penetrations shall be recessed within module wall and capped for protection during transportation.
 - b. Use of weather proof sealing gland (Roxtec or similar) shall be used for all piping penetrations.

Supporting Systems

1. Monitoring & Control (DCIM)
 - a. Standard set up for data communication from the supporting infrastructure and the environmental conditions from the Data Center. IP, ModBus (or equivalent)
2. Fire Detection & Suppression
 - a. Extinguishing media, control systems, and alarms to be defined by customer and meet local codes
 - b. Coordination with local agencies may be required
 - c. Considerations shall be made to manage and accommodate cooling and ventilation systems in coordination with fire suppression.
 - d. Novec 1230 fire extinguishing Media and Early detection system type VESDA Aspirating Smoke Detection (or equivalent)
3. Security
 - a. Access to door system by card reader (biometric system is an Option)
4. Lighting
 - a. LED Lighting in accordance with working environmental regulation demands

Transportation

1. Transport Considerations
 - a. All input and output power lines are disconnected.
 - b. Coolant pipes/water lines are disconnected and the coolant/water is completely drained and purged.
 - c. UPS batteries are removed from the IT Module.
 - d. All breakers are turned off (Open circuit).
 - e. Any loose items are secured or removed.
 - f. Outside ground connections are removed.
 - g. All doors are secured.
 - h. No other outside attachments remain (i.e. security cameras, cable tray, etc).

- i. Module is designed for lifting and transport of equipment load within the specified weights in the Module specification summary.
2. Lifting
 - a. Always adhere to local and national codes. All transport, lifting, and installation operations must be done by certified personnel.
 - b. An overhead crane is required for unloading and positioning of the IT Module. Sufficient preparations must be made to the site to accommodate the crane. The exact load distribution will not be known until the unit is constructed.
 - c. All lifting equipment must have the necessary capacity to withstand specified final, constructed weight of the module [including Factors of Safety].
 - d. Please note that the center of gravity of the IT Module does not align with the geometric center. One option is to use an “H” style Adjustable Lift Beam. Horizontality must be verified on site and the central lifting cable must be adjusted (in both perpendicular directions) before starting the lifting operation to ensure that no tilting or swinging occurs. The IT Module must be lifted using standard load spreading techniques from the lifting attachment points provided.
3. Leveling
 - a. The IT Module must be placed on a level foundation with continuous support at locations specified by manufacturer.

Site Preparation

1. Safety Information
 - a. All electrical, cooling system modifications and maintenance to and within the IT Module must be performed by a certified technicians. All work must comply with local and national codes.
 - b. Refer to the safety instructions for each component of the IT Module for specific safety requirements of said component. The instructions shall be provided by the manufacturer.
 - c. The IT Module is not intended for continuous human occupancy except for short-duration maintenance access.
 - d. Consult your local planning office for applicable codes and to review necessary permitting and guidelines for your specific site.
2. Foundation
 - a. A level base shall be supplied at the site to act as a foundation for the IT Module. The base must be capable of supporting the weight of the final unit distributed equally around the perimeter.
 - b. There should be sufficient foundation extending outward beyond the IT Module to allow the hold-down brackets to bolt into the foundation.
 - c. Site shall be graded to drain water away from the IT Module and foundation. The foundation should be raised by a minimum of 150mm above the surrounding ground surface level to prevent water ingress.

3. Power / water
 - a. Main feeder for low voltage support of the Data Center need to be prepared.
 - b. Tap water for humidification when required.
4. Clearance and Space Restrictions
 - a. Place IT Module away from objects which may impede performance, or damage the equipment.
 - b. Do not place the IT Module or any support equipment near or under trees or other objects which may become dislodged in a natural event (storm, earthquake, etc).
 - c. The site should be laid out in such a way as to diminish or prevent the possibility of a vehicular collision with the IT Module. It is also helpful to design the site so that a forklift or other material handling device can deliver equipment near the entry door.
 - d. Consult with manufacturer regarding planned routing of electrical lines, water/refrigerant piping, drain lines, grounding connections, and fastening points.
5. Environmental
 - a. Environmental conditions such as elevation, storm winds, snow loads, and max/min temperatures can affect performance and longevity of the module. Determine site specific conditions and specify minimum environmental requirements to the manufacturer.

Onsite Module Deployment

1. Base Anchors and Fixtures: Anchor locations/brackets to be provided by manufacturer.
2. Coordination of cable entrance locations and cable sizes between module manufacturer, installing contractor, and consultant must be performed to ensure proper installation and must follow all local and national codes for the application.
3. The upstream breaker should be sized based on the IT Module load, and the input wiring
4. Follow the breaker instructions provided with the IT Module for conductor installation.
5. Ensure the IT Module is properly grounded according to local codes.
6. Stairways, ramps, and access platforms must comply with all local and national codes. They must be suitable for in-service conditions. Stairways, ramps, and access platforms are not included with the IT Module.

Operations and Maintenance

1. Module to be delivered with the following:
 - a. Specifications and drawings
 - b. Operations and Maintenance manuals
2. Services and/or training services shall be available.
3. Operations and Maintenance procedures shall meet applicable Codes and Standards.

Appendix A

Example Drawings

- 1. Module
 - a. External

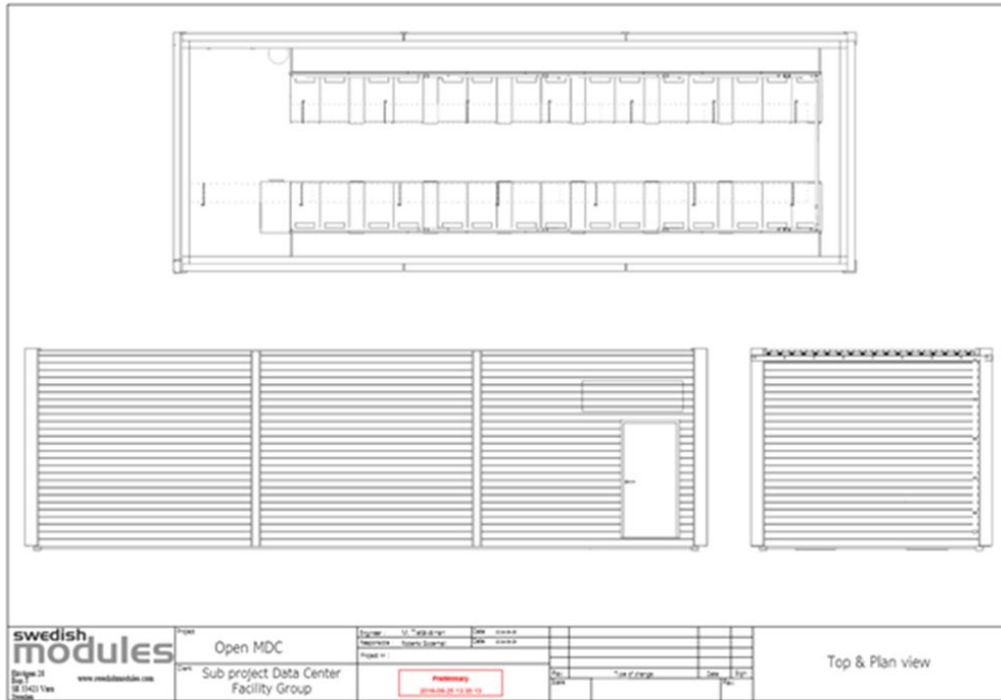

b. IT Space

Single module with UPS

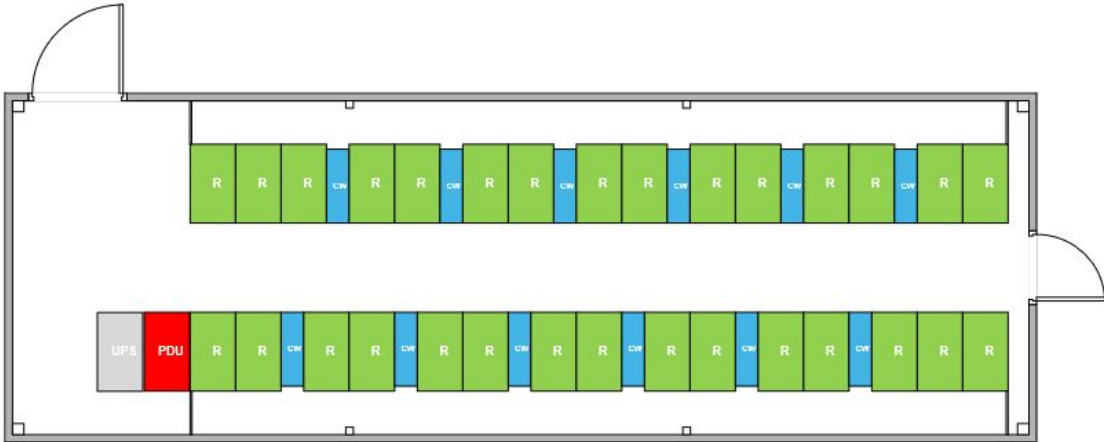

Single module without UPS

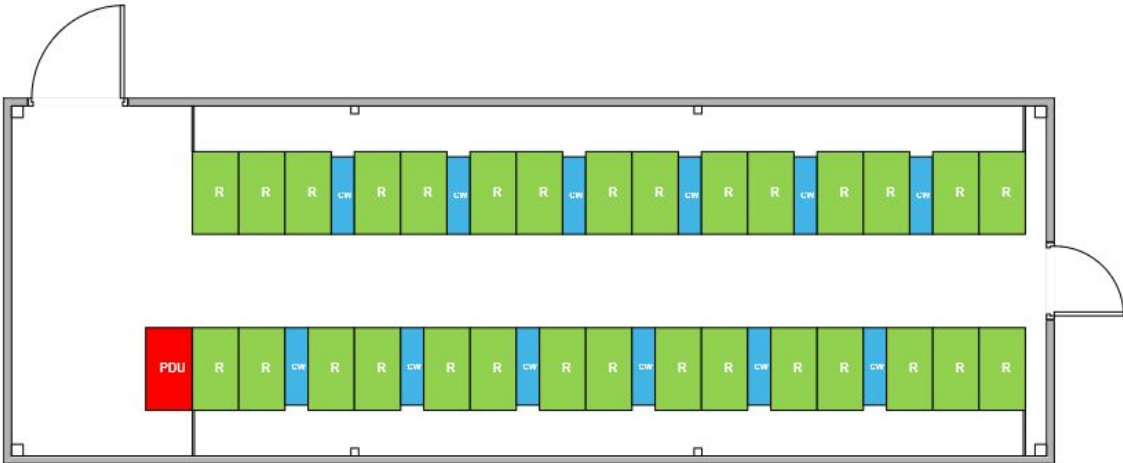

Three modules without UPS

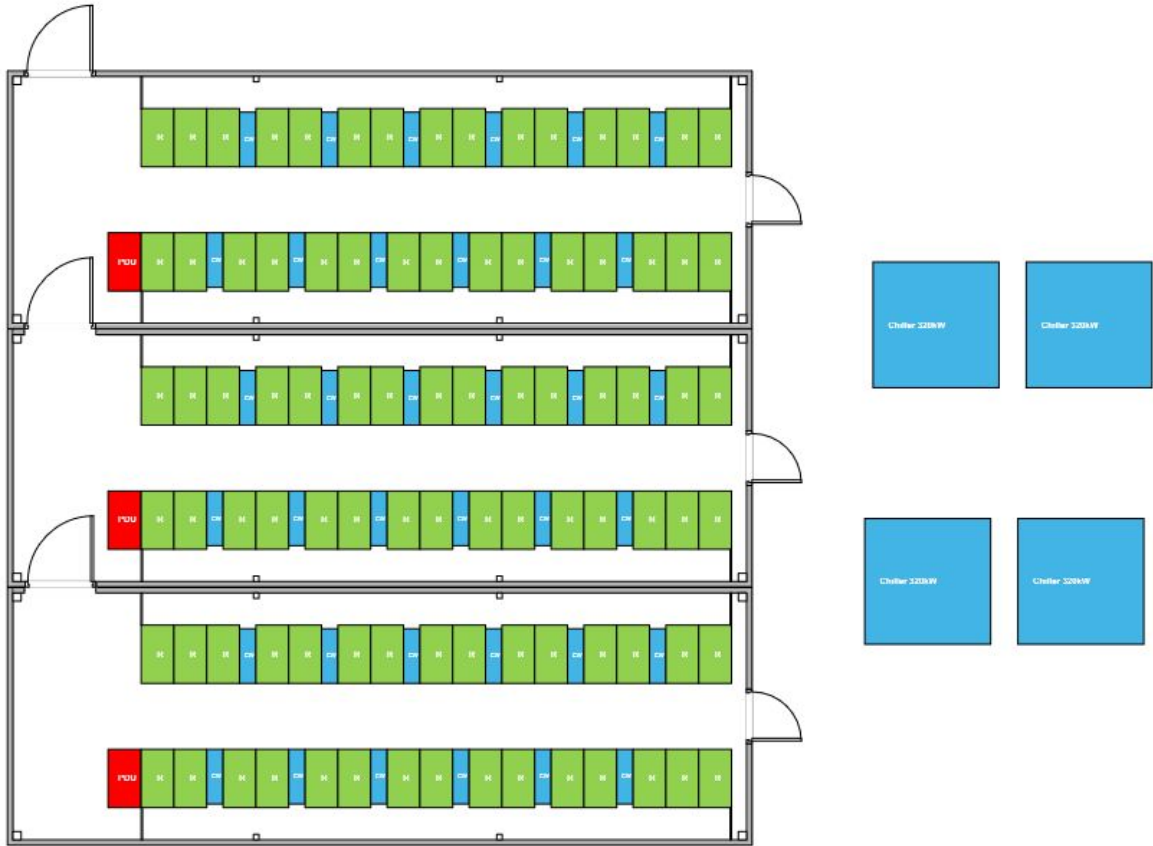

2. Electrical

Single module without UPS

BUSWAY CONFIGURATION

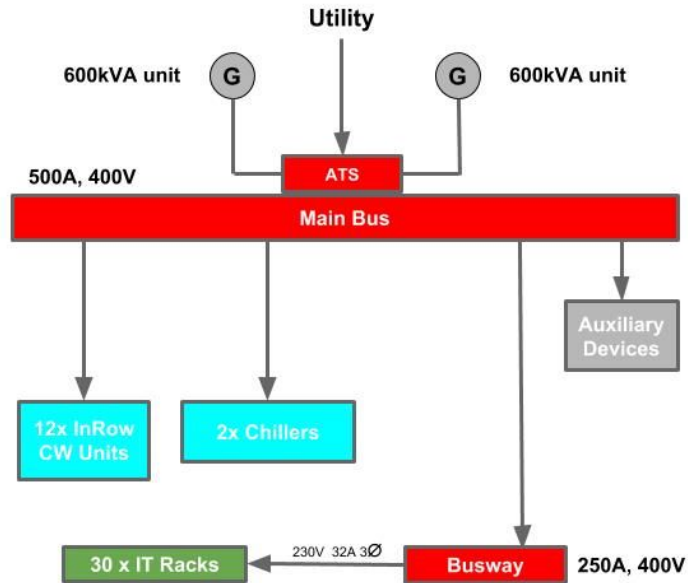

PDU CONFIGURATION

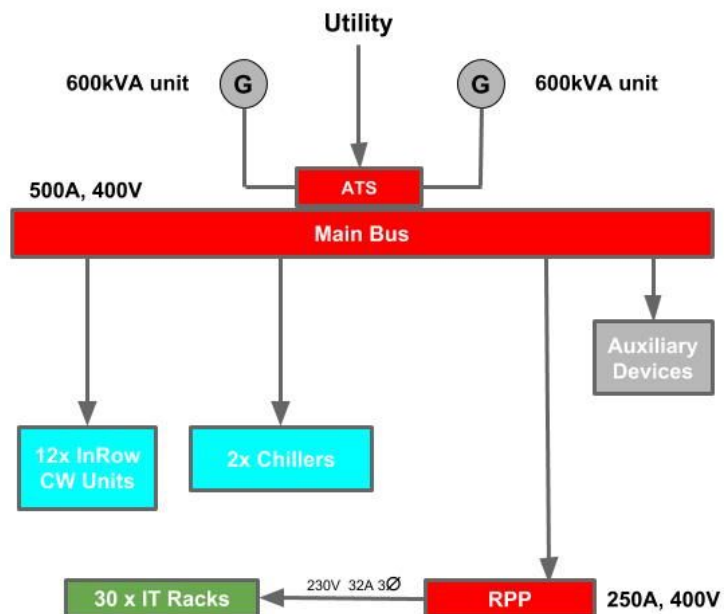

Three modules without UPS

BUSWAY CONFIGURATION (Three Modules 900kW)

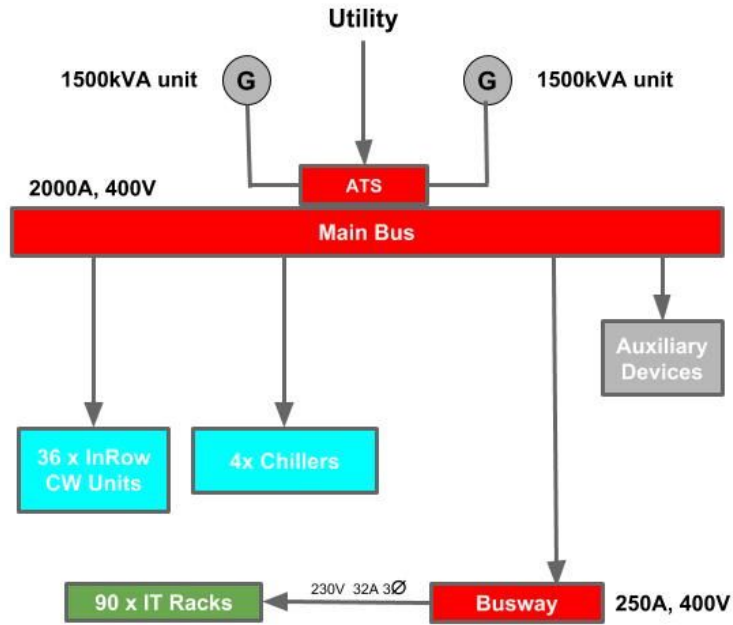

3. Cooling

Single module piping diagram

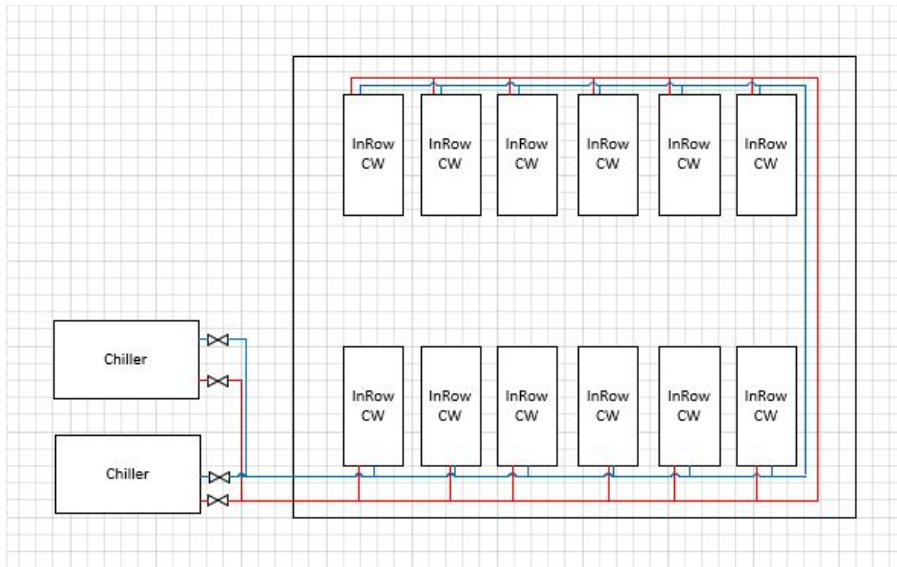

Three modules piping diagram

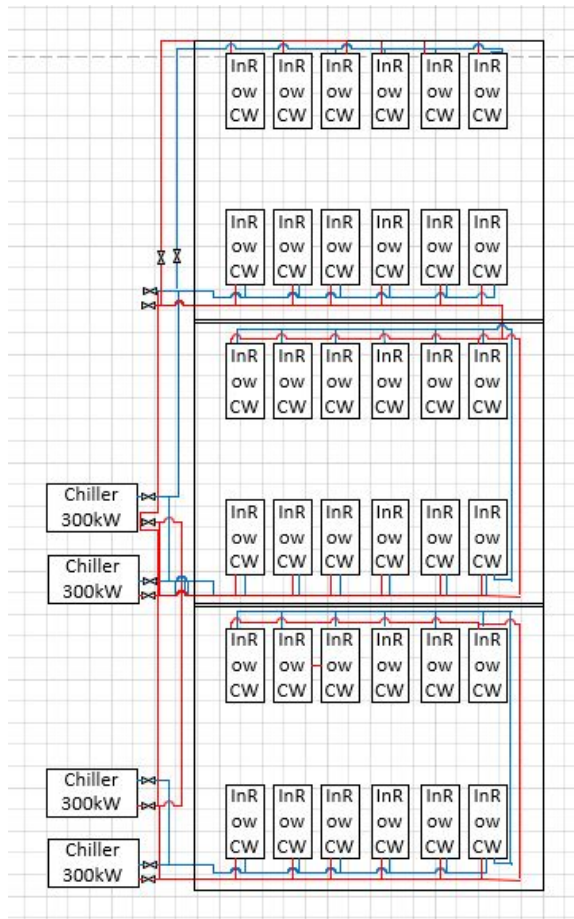

Revision History

Date	Version	Description
2019-02-05	1.0	Final Version for Review and Approval